

Table of contents

HD 5.5/50 EC Cage (1.107-087.0)	2
50 ELEC ROLL CAGE EXPLODED VIEW (0.251-022.0)	3
60 ELECTRICAL BOX (0.251-023.0)	8
70 VB UNLOADER (0.251-024.0)	10
80 HOSE & SPRAY GUN (0.251-025.0)	12
90 H-SERIES PUMP (0.251-026.0)	14

HD 5.5/50 EC Cage (1.107-087.0)

POS	Article no.	Description	Quantity	Unit
50	0.251-022.0	ELEC ROLL CAGE EXPLODED VIEW	1.000	ST
60	0.251-023.0	ELECTRICAL BOX	1.000	ST
70	0.251-024.0	VB UNLOADER	1.000	ST
80	0.251-025.0	HOSE & SPRAY GUN	1.000	ST
90	0.251-026.0	H-SERIES PUMP	1.000	ST

50 ELEC ROLL CAGE EXPLODED VIEW (0.251-022.0)

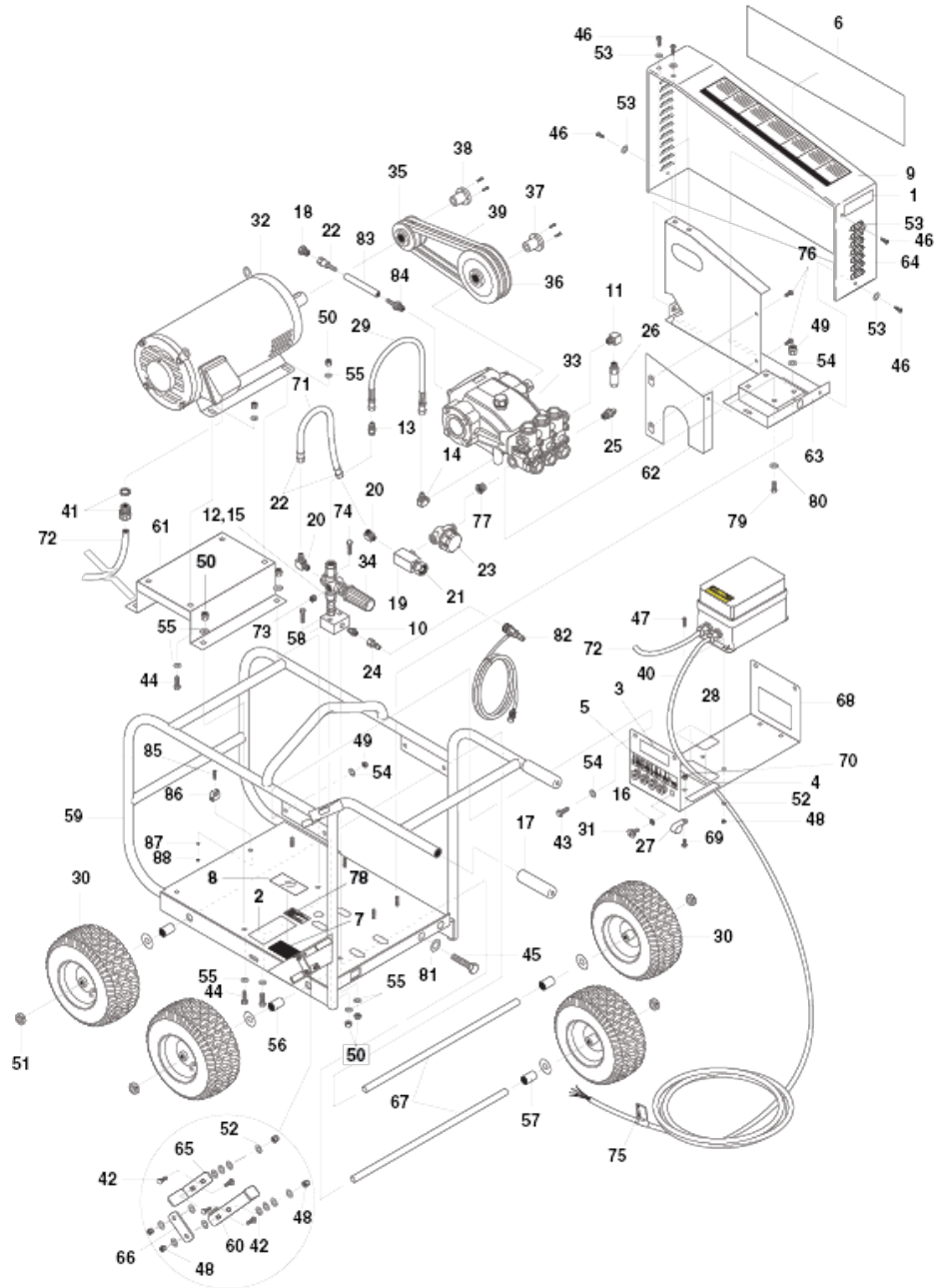

50 ELEC ROLL CAGE EXPLODED VIEW (0.251-022.0)

POS	Article no.	Description	Quantity	Unit	Remark
1	8.932-965.0	LABEL, WARNING-EXPOSED PULLEYS	1.000	ST	
2	9.803-842.0	LABEL, INSTRUCTIONS, BR	1.000	ST	
3		LABEL, RELIEVE PRESSURE (LEXAN)	1.000	ST	
4		LABEL,EQUIPMENT OPRATED BY TRAINED-LXAN	1.000	ST	
5	8.932-967.0	LABEL, NOZZLE, 0, 15, 25, 40, & SOAP	1.000	ST	
6	8.901-144.0	LABEL, HOTSY LOGO	1.000	ST	
6	9.800-047.0	LABEL, KARCHER, FRAME, LOGO	1.000	ST	
6	8.900-870.0	LABEL, SHARK LOGO DIE-CUT	1.000	ST	
6	8.750-465.0	LABEL, LANDA, SHEET METAL GUARD	1.000	ST	
7	9.800-013.0	LABEL,ASSLD USA INTENDED FOR INDOOR USE	1.000	ST	
8	9.800-034.0	Label clear lexan 4.30" x 4.70"	1.000	ST	
9	9.800-036.0	LABEL, WARNING, PICTORIAL, SMALL	1.000	ST	
10	9.802-011.0	HEX NIPPLE,4STEEL PIPE,3/8"x3/8"/6000PSI	1.000	ST	
11	9.802-030.0	STREET ELBOW, 3/8"MPT x 3/8"FPT/4500 PSI	1.000	ST	
12	9.802-036.0	Nipple 1/2" JIC x 3/8" MPT, STEEL	1.000	ST	
13	9.802-037.0	Nipple 1/2 JIC x 3/8 FPT, STEEL	1.000	ST	
14	9.802-039.0	Elbow 1/2" JIC x 3/8" MPT STEEL	1.000	ST	
15	9.802-048.0	Swivel 1/2" JIC FPT, 3/8" MPT STEEL	1.000	ST	
16	9.802-064.0	GROMMET, RUBBER, NOZZLE HOLDER	5.000	ST	
17	9.802-070.0	GRIP,1' ROUND,HNDLE,691887,SANTPRNE RB	2.000	ST	
18	9.802-126.0	PLUG, 1/2" JIC FLARE, 639F-8	1.000	ST	
19	9.802-118.0	TEE, 1/2" BRANCH MALE, BRASS	1.000	ST	
20	9.802-131.0	ELBOW, 1/2" MSAE x 1/2" MPT, BRASS	2.000	ST	
21	9.802-146.0	SWIVEL, 1/2" MP x 3/4" GHF W/STRAINER	1.000	ST	
22	9.802-151.0	SWIVEL, 1/2" BARB x 1/2"JIC, FEM/BRASS	2.000	ST	
23	9.802-163.0	FILTER, 1/2" MPT, PA	1.000	ST	
24	9.802-168.0	COUPLER, 3/8" PLUG, FEMALE/11,000 PSI	1.000	ST	
24	9.802-168.0	COUPLER, 3/8" PLUG, FEMALE/11,000 PSI	1.000	ST	
25	9.802-182.0	Thermo relief 145F 1/2'PTPX1/4	1.000	ST	
25	9.802-182.0	Thermo relief 145F 1/2'PTPX1/4	1.000	ST	
26	9.803-843.0	SAFETY RELIEF VALVE 6GPM/6000	1.000	ST	
26	9.803-843.0	SAFETY RELIEF VALVE 6GPM/6000	1.000	ST	
27	9.802-206.0	CLAMP, WIRE/TUBE, 1.312 DIA	1.000	ST	(230V)

50 ELEC ROLL CAGE EXPLODED VIEW (0.251-022.0)

POS	Article no.	Description	Quantity	Unit	Remark
27	9.802-206.0	CLAMP, WIRE/TUBE, 1.312 DIA	1.000	ST	
27	9.802-204.0	CLAMP, WIRE/TUBE, .75 DIA	1.000	ST	(460V)
27	9.802-204.0	CLAMP, WIRE/TUBE, .75 DIA	1.000	ST	
28	9.802-163.0	FILTER, 1/2" MPT, PA	1.000	ST	
28	9.802-071.0	TRIM, 750 B2 X 1/16. BLACK	1.660	FT	
29	8.918-421.0	Hose 3/8"X 14",2 WIRE, PRESSURE LO	1.000	ST	
30	9.802-271.0	WHEEL & TIRE ASSY, 13" STEEL RIM	4.000	ST	
31		NOZZLE SS 1/4' #4.5X25 Q-STYLE	1.000	ST	
31		NOZZLE SS 1/4' #4.5X15 Q-STYLE	1.000	ST	
31	9.803-813.0	Nozzle SS 1/4" 4.5X40 Q-STYLE	1.000	ST	
31		NOZZLE SS 1/4' #4.5X 0 Q-STYLE	1.000	ST	
31	9.802-311.0	NOZZLE 40 X 65, Q-STYLE BR	1.000	ST	
32		WIRE NUT,BROWN,TWISTER,8-22 AWG	6.000	ST	(230V/3PH) NOT SHOWN
32	9.800-040.0	LABEL, GROUND SYMBOL	1.000	ST	(Motor) NOT SHOWN
32		MOTOR, 20HP 3PH 230/460V, 1800RPM, EM251	1.000	ST	
33	8.921-659.0	PUMP, HOTSYS HX5450R 5.4@5000, 1740RPM	1.000	ST	
33	8.921-655.0	PUMP, LANDA LX5450R 5.4@5000, 1740RPM	1.000	ST	
33	8.921-657.0	PUMP, KARCHER KX5450R 5.4@5000, 1740RPM	1.000	ST	
34	9.802-360.0	UNLOADER VB350(MOD.VB7)4700/6.	1.000	ST	
35	9.802-394.0	PULLEY, 3TB40	1.000	ST	
36	9.803-979.0	PULLEY, 3BK 50H	1.000	ST	
37	9.802-402.0	BUSHING, H X 24MM	1.000	ST	
38	9.803-980.0	BUSHING, P1 X 1-5/8	1.000	ST	
39	8.749-965.0	BELT, 3/BX42, BANDED	1.000	ST	
40	9.803-992.0	CORD, SERV, 4/4, SEOWW, /FT	15.000	FT	(230V/3PH)
40	9.802-437.0	CORD, SERV, 10/4, SEOWW, /FT	15.000	FT	(460V)
41	9.803-975.0	STRAIN RELIEF,CG100-1050,1'BLK(4/4 COR	1.000	ST	
41	9.803-279.0	STRAIN RELIEF,CG100-750,1" YEL(10-4COR	1.000	ST	
41	9.803-280.0	LOCKNUT, 1" CONDUIT	1.000	ST	
42	9.802-705.0	BOLT, 1/4"-20 x 1" CARRIAGE ZINC	4.000	ST	
43	9.802-722.0	BOLT, 3/8 X 1-1/4", NC HH	4.000	ST	
44	9.802-720.0	BOLT, 3/8" x 1", NC HH	8.000	ST	
45	9.803-845.0	BOLT, 1/2 X 5" NC HH TAP, ALL THREAD	1.000	ST	

50 ELEC ROLL CAGE EXPLODED VIEW (0.251-022.0)

POS	Article no.	Description	Quantity	Unit	Remark
46	9.802-765.0	SCREW, 1/4-20 X 1/2", BH BLACK	5.000	ST	
47	9.802-770.0	SCREW, 1/4" X 1", BH SOC CS	4.000	ST	
48	9.802-773.0	Nut 1/4-20 ESNA NC	8.000	ST	
49	9.802-776.0	NUT, 5/16-18, ESNA	8.000	ST	
50	9.197-003.0	3/8-16 NE NYLON INSERT L/N ZC 5UM WHITE	10.000	ST	
51	9.802-782.0	COLLAR, 5/8" BORE SHAFT 3010	8.000	ST	
52	9.802-802.0	WASHER, 1/4" FLAT SAE ZINC	16.000	ST	
53	9.802-803.0	WASHER, 1/4" FLAT, SAE BLK ZINC	5.000	ST	
54	9.802-804.0	WASHER, FLAT 5/16"ID USS ZINC	12.000	ST	
55	9.802-807.0	WASHER, 3/8", SAE, FLAT ZINC	16.000	ST	
56	9.802-810.0	WASHER, 5/8", FLAT, SAE ZINC	8.000	ST	
57	9.802-820.0	SLEEVE, 0,656X1,25X0,65 NYLON	4.000	ST	
58	9.802-870.0	BLOCK, UNLOADER, 3/8 X 3/8, 1.25, STEEL	1.000	ST	
59	9.802-964.0	ASSY, WELD, CW CAGE, LRG, BLACK	1.000	ST	
59	8.912-486.0	ASSY, WELD, CAGE, CW RED	1.000	ST	
60	9.802-966.0	Grip, Hand	1.000	ST	
60	8.912-495.0	HANDLE, BRAKE, CW CAGE, RED	1.000	ST	
61		ASSY, WELD, MOTOR RAIL, ELEC, CW LRG	1.000	ST	
61		ASSY,WELD,MTR RAIL, ELEC CW LRG BDE5	1.000	ST	
62		ASSY, WELD, ELEC, GUARD REAR, CW LRG	1.000	ST	
63		ASSY, WELD,SLIDER,ELEC,CW LRG BDE5	1.000	ST	
63		ASSY, WELD, SLIDER, ELEC, CW LRG	1.000	ST	
64		GUARD, BELT, FRONT, ELEC, CW LRG	1.000	ST	
65	9.802-996.0	BRACKET, BRAKE PAD	1.000	ST	
65	8.912-019.0	BRACKET, BRAKE PAD, RED	1.000	ST	
66	9.802-997.0	Leverage	1.000	ST	
66	8.912-020.0	LINKAGE, BRAKE, RED	1.000	ST	
67	8.918-839.0	AXLE LRG CW CAGE, 31.25"SAME 9.803-037.0	2.000	ST	
68		BRACKET, E-BOX, CW CAGE, LRG, MPE	1.000	ST	
68		BRACKET, E-BOX, CW CAGE, LRG MPES	1.000	ST	
69	9.802-770.0	SCREW, 1/4" X 1", BH SOC CS	1.000	ST	(230V/3PH)
69	9.802-759.0	SCREW, 10/32" x 1/2" BHSOC BLK	1.000	ST	
70	9.802-773.0	Nut 1/4-20 ESNA NC	1.000	ST	(230V/3PH)

50 ELEC ROLL CAGE EXPLODED VIEW (0.251-022.0)

POS	Article no.	Description	Quantity	Unit	Remark
70	9.802-695.0	NUT, 10/32" KEPS	1.000	ST	(460V/3PH)
71	9.802-259.0	HOSE, 1/2" PUSH-ON, /FT	15.000	ST	
72	9.802-437.0	CORD, SERV, 10/4, SEOOW, /FT	37.000	FT	(460V/3PH)
72	9.803-992.0	CORD, SERV, 4/4, SEOOW, /FT	37.000	FT	(230V/3PH)
73	9.802-124.0	HEX SOCKET HEAD PLUG, 1/4"	1.000	ST	
74	9.802-728.0	BOLT, 3/8-16 x 2", HH ZINC	2.000	ST	
75	8.932-969.0	LABEL, WARNING, SERVICE CORD	1.000	ST	
76	9.802-765.0	SCREW, 1/4-20 X 1/2", BH BLACK	2.000	ST	
77	9.802-148.0	ADAPTER 1/2'F X 1/2'M BRASS	1.000	ST	
78	9.800-049.0	LABEL, MANUFACTURER'S CLEANING SOLUTION	1.000	ST	
79	9.802-744.0	BOLT, 10mm x 20mm, HH ZINC	4.000	ST	
80	9.802-816.0	WASHER, 7/16", SPLIT RING LOCK, 780481	4.000	ST	
81	9.802-809.0	WASHER, 1/2" FLAT SAE	1.000	ST	
82	9.802-226.0	DOWNSTREAM INJECTOR ASSY, 5000 PSI	1.000	ST	
83	9.802-259.0	HOSE, 1/2" PUSH-ON, /FT	20.000	ST	
84	9.802-156.0	HOSEBARB PUSHON 1/2Bx3/8 MPT	1.000	ST	
85	9.802-771.0	SCREW, 10/32" X 3/4", BH SOC CS	1.000	ST	
86	9.802-203.0	CLAMP, 1/2" RO-CLIP, KLEINHUIS P/N 796/1	1.000	ST	
87	9.802-802.0	WASHER, 1/4" FLAT SAE ZINC	1.000	ST	
88	9.804-567.0	*NUT, 10/32', ESNA	1.000	ST	

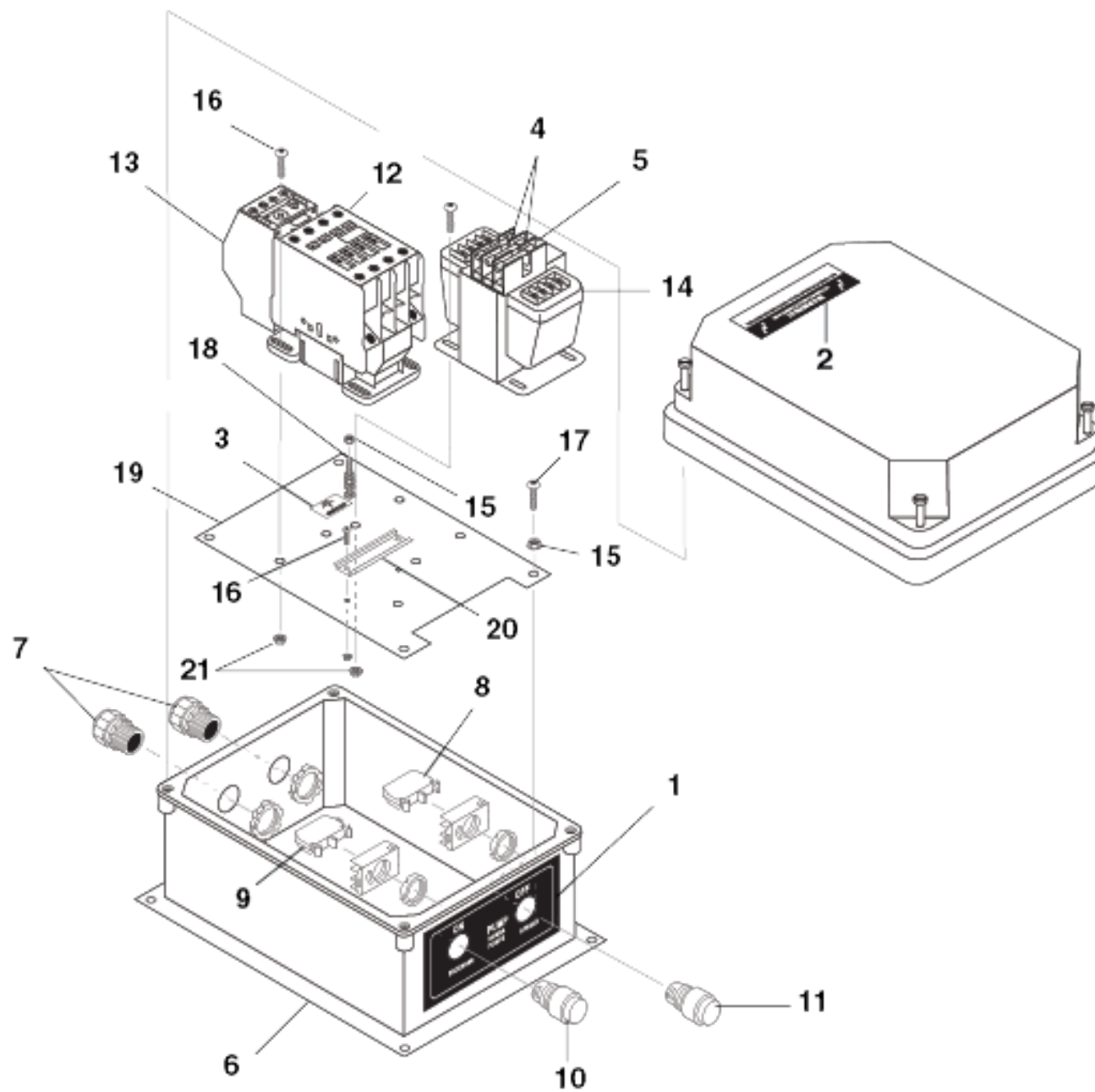

60 ELECTRICAL BOX (0.251-023.0)

POS	Article no.	Description	Quantity	Unit	Remark
1		LABEL, ON/OFF, PE PUSH BUTTONS	1.000	ST	
2	9.800-016.0	LABEL, DISCONNECT POWER SUPPLY	1.000	ST	
3	9.800-040.0	LABEL, GROUND SYMBOL	1.000	ST	
4	8.933-007.0	FUSE, KTK-R1 600V MIDGET FUSE	2.000	ST	(230V/3PH)
4	9.802-462.0	FUSE, KTK-R-1/2 600V MIDGET FUSE	2.000	ST	(460V/3PH)
5	9.802-463.0	FUSE, PAPER, BUSS FNM-1/2,250V MIDGET TD	1.000	ST	
6		BOX, PLASTIC, 10X8X6.19, RVJ1008W	1.000	ST	
7	9.803-975.0	STRAIN RELIEF,CG100-1050,1'BLK(4/4 COR	2.000	ST	
7	9.802-518.0	STRAIN RELIEF, LT, STR, 3/4 NPT .49-.71D	2.000	ST	(460V/3PH)
7	9.803-280.0	LOCKNUT, 1" CONDUIT	2.000	ST	
7	9.802-526.0	LOCKNUT, 3/4" 8465	2.000	ST	(460V/3PH)
8		BLOCK, CONTACT, N/C, CH E22B1	1.000	ST	
9		BLOCK, CONTACT, N/O, CH E22B2	1.000	ST	
10		SWITCH, GREEN PB, CH E22PB3	1.000	ST	
11		SWITCH, RED PB, CH E22EB2	1.000	ST	
12		CONTACTOR, DP, C25FNY44AL, 60 AMP	1.000	ST	(230V/3PH)
12		CONTACTOR, DP C25DNY155AL, 50 AMP	1.000	ST	
13	8.724-307.0	OVERLOAD, XTOB057DC1DP, 40.0 - 57.0	1.000	ST	(230V/3PH)
13	8.724-305.0	OVERLOAD, XTOB032CC1DP, 24.0 - 32.0	1.000	ST	(460V/3PH)
14	9.802-551.0	TRANSFRMER,240/480V-120V,50/60HZ,.050KVA	1.000	ST	
15	9.802-695.0	NUT, 10/32" KEPS	7.000	ST	
16	9.802-750.0	SCREW, 8-32 X 1/2 M TPG PH PNH, BLACK	7.000	ST	
17	9.802-759.0	SCREW, 10/32" x 1/2" BHSOC BLK	4.000	ST	
18	9.802-762.0	SCREW, 10/32" x 1-1/4" RH, SL, BLK	1.000	ST	
19		STANDOFF, CW CAGE LRG, MPE	1.000	ST	
20	9.802-457.0	DIN RAIL,35MM	3.000	IN	
21	9.802-785.0	NUT, 8/32", KEPS	6.000	ST	

VB UNLOADER EXPLODED VIEW

9.802-360.0
 VB350/4 10.5 GPM at 5100 PSI

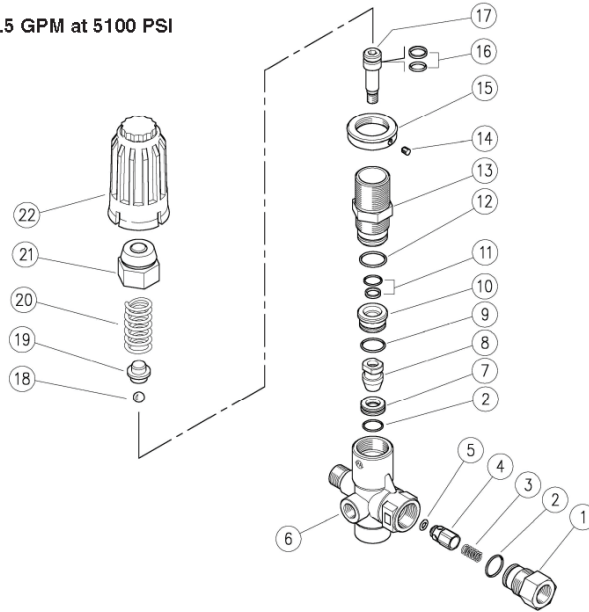

VB UNLOADER EXPLODED VIEW PARTS LIST

ITEM	PART #	DESCRIPTION	QTY	ITEM	PART #	DESCRIPTION	QTY
	1	3/8 Bsp F Nipple	1	16	*	VB280-350 Val. Pist. Seal	1
	2	* O-Ring, 1.78 x 15.6 mm	2	17		M8 Piston	1
	3	Spring	1	18	*	Sst 11/32" Ball	1
	4	SST Check Valve	1	19		Spring Guide	1
	5	* O-Ring, 3 x 6mm	1	20		4.5 x 47 mm Spring (60.1700.00)	1
	6	VB280-350 Brass Body	1	21		Brass Cap	1
	7	* Seat	1	22		VB350.4 Red Plastic Knob (60.1700.00)	1
	8	* M 8 Shutter	1				
	9	* O-Ring, 1.78 x 17.17 mm	1				
	10	Spacer	1				
	11	* VB280-350 Val. Pist. Seal	1				
	12	* O-Ring, 1.78 x 20.35 mm	1				
	13	Piston Housing (60.1700.00)	1				
	14	M 4 x 4 mm Dowel	1				
	15	Lock Nut	1				

* Available in Repair Kit :
 K1 9.800-106.0 VB350 Repair Kit

70 VB UNLOADER (0.251-024.0)

POS	Article no.	Description	Quantity	Unit	Remark
1	9.802-360.0	UNLOADER VB350(MOD.VB7)4700/6.	1.000	ST	VB350/4 10.5 GPM at 5100 PSI

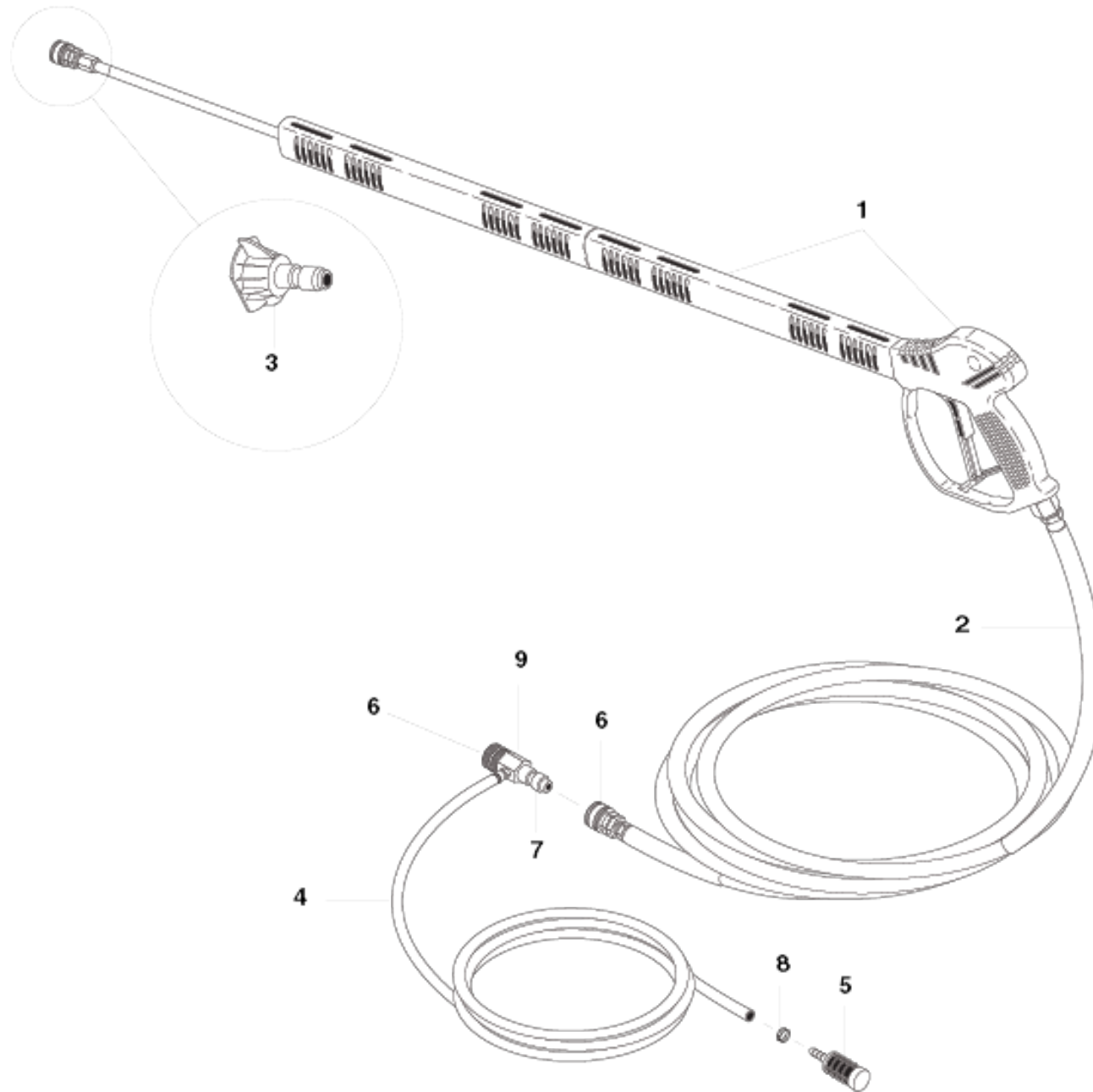

80 HOSE & SPRAY GUN (0.251-025.0)

POS	Article no.	Description	Quantity	Unit	Remark
1	9.802-228.0	Gun W/WAND (5000 PSI), W/COUPLER	1.000	ST	
2		HOSE 3/8" X50, 2W,TS,SO-SW HIGH PRESS CP	1.000	ST	(MPE)
2	8.739-346.0	HOSE, 3/8X50', 2W, TS, KA, SO-SW, HP CP	1.000	ST	(BRE, HD)
2		NLA, HOSE, 3/8X5', 2W, TF, SH, 1/2'SO-	1.000	ST	(BDE)
3	9.803-813.0	Nozzle SS 1/4" 4.5X40 Q-STYLE	1.000	ST	
3		NOZZLE SS 1/4' #4.5X15 Q-STYLE	1.000	ST	
3		NOZZLE SS 1/4' #4.5X25 Q-STYLE	1.000	ST	
3		NOZZLE SS 1/4' #4.5X 0 Q-STYLE	1.000	ST	
3	9.802-311.0	NOZZLE 40 X 65, Q-STYLE BR	1.000	ST	
4	9.802-251.0	TUBE 1/4" x 1/2", CLEAR VINYL /FT	6.000	ST	
5	9.802-160.0	CHEM STRAINER, PLASTIC, W/O CHECK VALVE	1.000	ST	
6	9.802-167.0	Coupler 3/8" SOCKET, FEMALE/11,000 PSI	1.000	ST	
7	9.802-168.0	COUPLER, 3/8" PLUG, FEMALE/11,000 PSI	1.000	ST	
8	6.390-126.0	CLAMP, HOSE, .46-, .54 ST	2.000	ST	
9	9.802-226.0	DOWNSTREAM INJECTOR ASSY, 5000 PSI	1.000	ST	

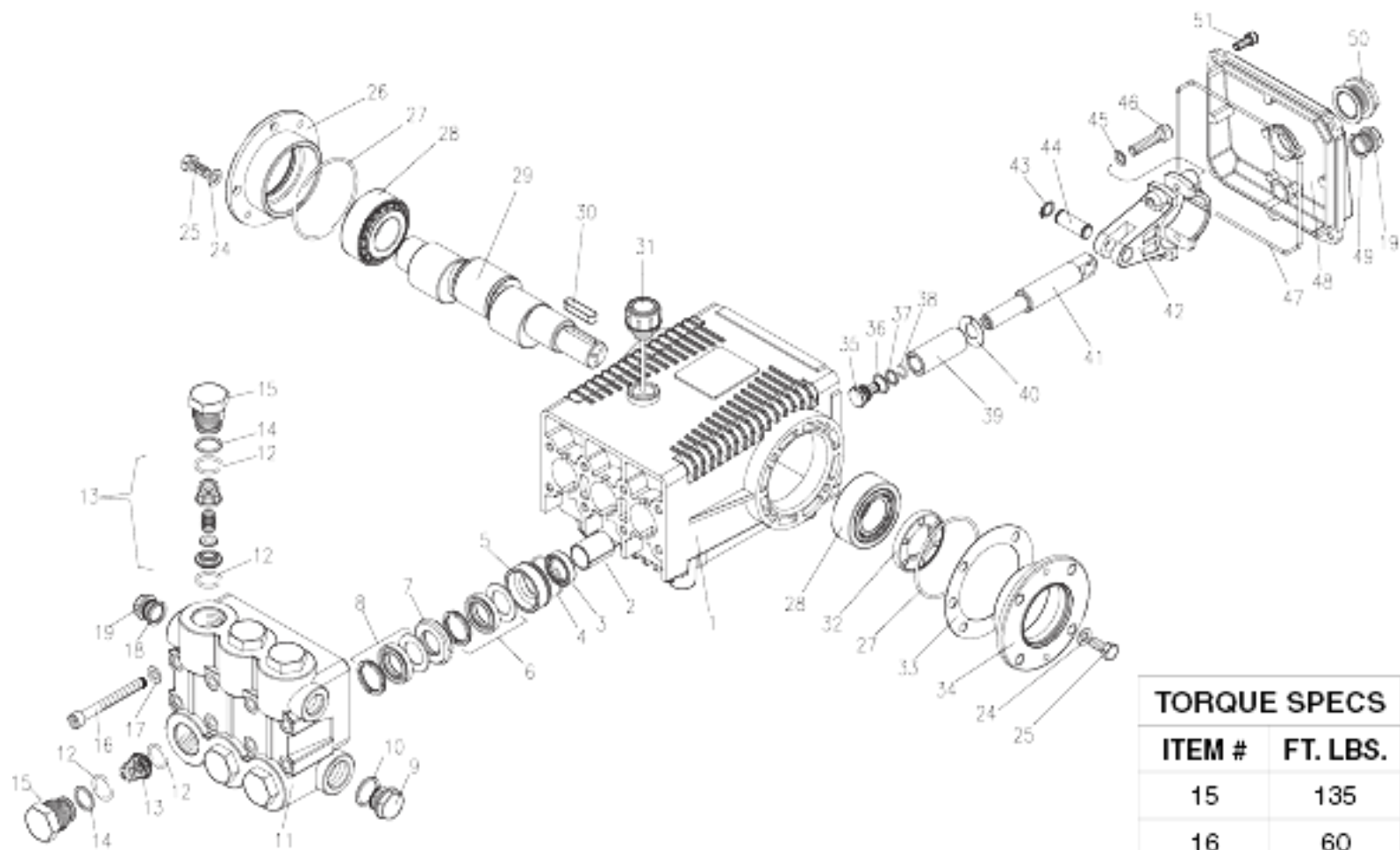

TORQUE SPECS	
ITEM #	FT. LBS.
15	135
16	60
25	18
35	4.5
46	30
51	7.6

90 H-SERIES PUMP (0.251-026.0)

POS	Article no.	Description	Quantity	Unit
1	8.921-657.0	PUMP, KARCHER KX5450R 5.4@5000, 1740RPM	1.000	ST
10	8.921-659.0	PUMP, HOTSY HX5450R 5.4@5000, 1740RPM	1.000	ST
20	8.921-655.0	PUMP, LANDA LX5450R 5.4@5000, 1740RPM	1.000	ST