

Spare parts list

(1.783-324.0) Pivot

Table of contents

Pivot (1.783-324.0)	3
3 Spare parts list Pivot (5.971-060.0)	4
10 Retaining bracket and switch	5
11 Retaining bracket	6
12 Switch	8
20 Top part	10
30 Bottom part individual parts	12
31 Brush housing	13
32 Transmission	15
40 Accessories pad roll	18
3 Hub pad roll BR VS (5.120-313.0)	20

Pivot (1.783-324.0)

POS	Article no.	Description	Quantity	Unit
3	5.971-060.0	Spare parts list Pivot	1.000	ST

3 Spare parts list Pivot (5.971-060.0)

POS	Description	Quantity	Unit
10	Retaining bracket and switch	1.000	ST
20	Top part	1.000	ST
30	Bottom part individual parts	1.000	ST
40	Accessories pad roll	1.000	ST

10 Retaining bracket and switch

POS	Description	Quantity	Unit
11	Retaining bracket	1.000	ST
12	Switch	1.000	ST

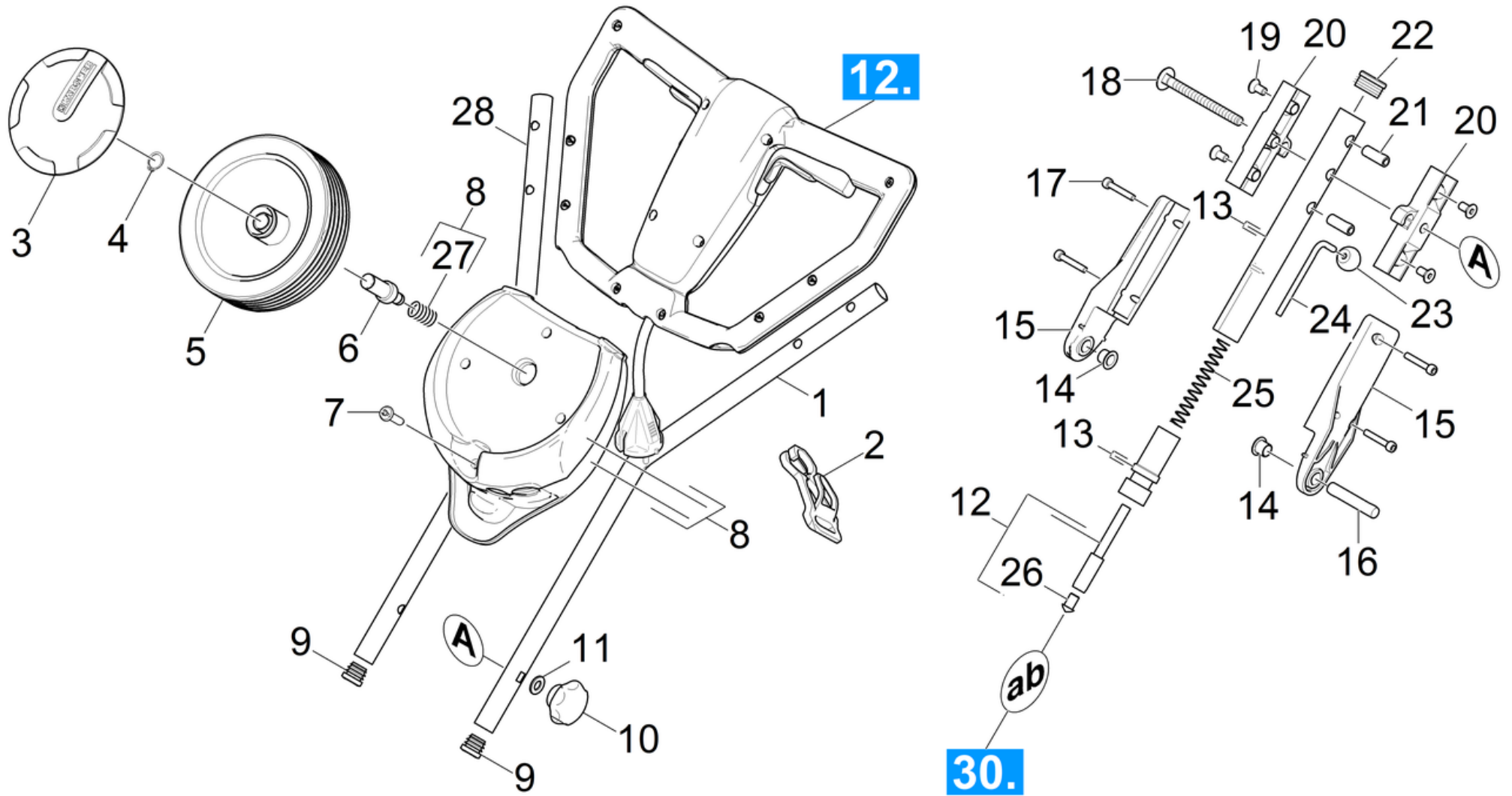

11 Retaining bracket

POS	Article no.	Description	Quantity	Unit	Foot note text
1	5.034-819.0	Retaining bracket top part	2.000	ST	
2	6.641-776.0	Strain relief	1.000	ST	
3	6.435-349.0	Wheel cap black neutrally	2.000	ST	
4	7.343-005.0	Locking ring 16x1-FST-PHR DIN 471	2.000	ST	
5	6.435-196.0	Wheel D 180	2.000	ST	
6	5.034-795.0	Axle transport wheel	2.000	ST	
7	7.303-108.0	Screw 5x20 -10.9-R2R (In6Rd)	1.000	ST	
8	4.783-003.0	Set wheel vat	1.000	ST	
9	6.368-419.0	Drain plug pipe Ø 18-20mm	2.000	ST	
10	6.321-246.0	Star grip M 10	1.000	ST	YELLOW
10	6.321-028.0	Star grip DIN 6336	1.000	ST	BLACK
11	7.312-005.0	Washer 10-200HV-A3E ISO 7089	1.000	ST	
12	4.034-162.0	Spring catch bolt cap	1.000	ST	
13	4.034-161.0	Retaining bracket bottom part complete B	1.000	ST	
14	6.347-084.0	Flanged bushing	2.000	ST	
15	5.031-506.0	Moulded part push handle	2.000	ST	
16	5.316-852.0	Bolt joint push handle	1.000	ST	
17	7.306-025.0	Cylinder head screw M 6x35-8.8-A2E ISO4	4.000	ST	
18	7.303-201.0	Saucer-head screw M10x110-ST-A0P DIN 60	1.000	ST	
19	7.305-637.0	Countersunk screw M8x16-A2-70 ISO 10642	4.000	ST	
20	5.034-822.0	Clamping part shearing shackle	2.000	ST	
21	5.110-825.0	Sleeve with female thread	2.000	ST	
22	6.385-783.0	Plug	1.000	ST	
23	7.321-030.0	Spherical head C 25-KU.sw DIN 319	1.000	ST	
24	5.034-821.0	Bar push handle lock-in position	1.000	ST	
25	5.332-320.0	Helical spring	1.000	ST	
26	5.368-002.0	Cap bolt	1.000	ST	
27	5.332-981.0	Pressure spring	2.000	ST	
28	4.034-207.0	Retaining bracket top part replacement B	1.000	ST	

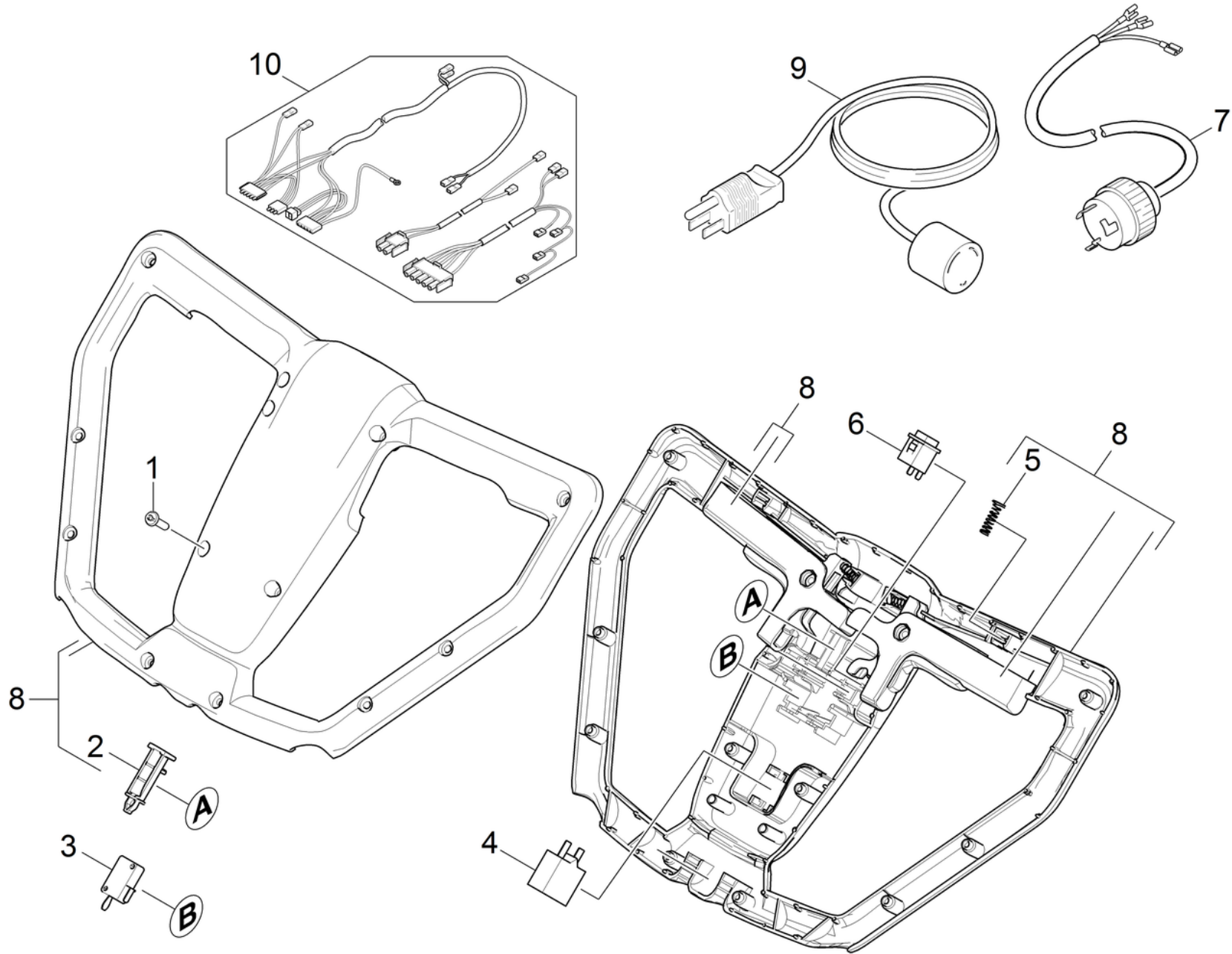

12 Switch

POS	Article no.	Description	Quantity	Unit
1	7.303-108.0	Screw 5x20 -10.9-R2R (In6Rd)	12.000	ST
2	5.050-433.0	Slide of a press switch	1.000	ST
3	6.630-426.0	Main switch	2.000	ST
4	6.630-428.0	Motor protecting switch 9A	1.000	ST
5	5.332-944.0	Spring conical	5.000	ST
6	6.630-427.0	Switch water pump	2.000	ST
7	6.649-696.0	Power cable SaberBlade 16	1.000	ST
8	4.783-007.0	Set operating unit replacement	1.000	ST
9	8.623-411.0	CORD SET,14/3 SJTW-A X 50' YLW	1.000	ST
10	6.650-485.0	Cable harness BRS 40/1000C KNA	1.000	ST

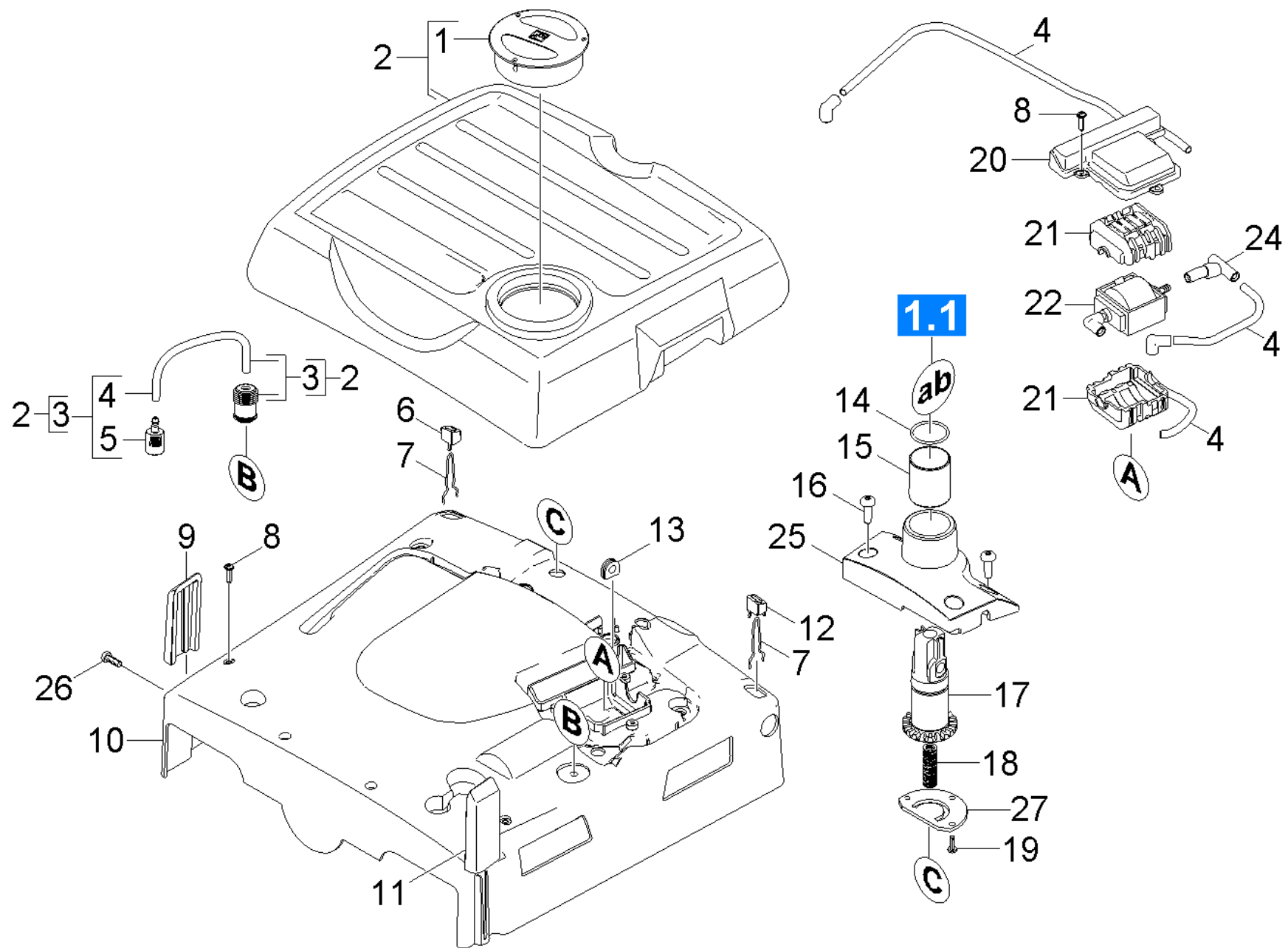

20 Top part

POS	Article no.	Description	Quantity	Unit	Foot note text
1	5.063-650.0	Cover	1.000	ST	BLACK
1	5.050-359.0	Cover metering fresh water	1.000	ST	YELLOW
2	4.034-017.0	Tank complete replacement Pivot	1.000	ST	BLUE
3	4.034-159.0	Valve tank BRS	1.000	ST	
4	6.388-216.0	Hose DN 5	4.000	M	TO ORDER AS CUT GOODS
5	5.731-664.0	Filter with weight	1.000	ST	
6	5.050-448.0	Pusher rear transport wheel	1.000	ST	
7	5.034-839.0	Spring transport wheel	2.000	ST	
8	7.303-108.0	Screw 5x20 -10.9-R2R (In6RD)	9.000	ST	
9	5.050-516.0	Ram protection right	1.000	ST	
10	5.050-909.0	Cover brush housing Pivot	1.000	ST	
11	5.050-517.0	Ram protection left	1.000	ST	
12	5.050-447.0	Pusher front transport wheel	1.000	ST	
13	6.648-064.0	Cable bushing	2.000	ST	
14	6.362-605.0	O-Ring seal 36,17x 2,62	1.000	ST	
15	6.403-042.0	Plain bearing 40/44x50	1.000	ST	
16	7.303-069.0	Screw M 8x25-ST-R3R (IN6RD)	4.000	ST	
17	5.033-479.0	Moulded part beam joint	1.000	ST	
18	6.330-140.0	Pressure spring	1.000	ST	
19	7.306-193.0	Screw M6x16 -A2-70 (In6Rd)	3.000	ST	
20	5.050-410.0	Cover pump	1.000	ST	
21	5.050-408.0	Bearing pump	2.000	ST	
22	6.473-532.0	Motor pump 120V 60Hz	1.000	ST	
24	4.050-956.0	Check valve	1.000	ST	
25	5.050-527.0	Flange drawbar worked	1.000	ST	
26	6.303-057.0	Countersunk screw 5,0X 16-ST-A2R	2.000	ST	
27	4.060-835.0	Plate stop swivel joint	1.000	ST	

30 Bottom part individual parts

POS	Description	Quantity	Unit
31	Brush housing	1.000	ST
32	Transmission	1.000	ST

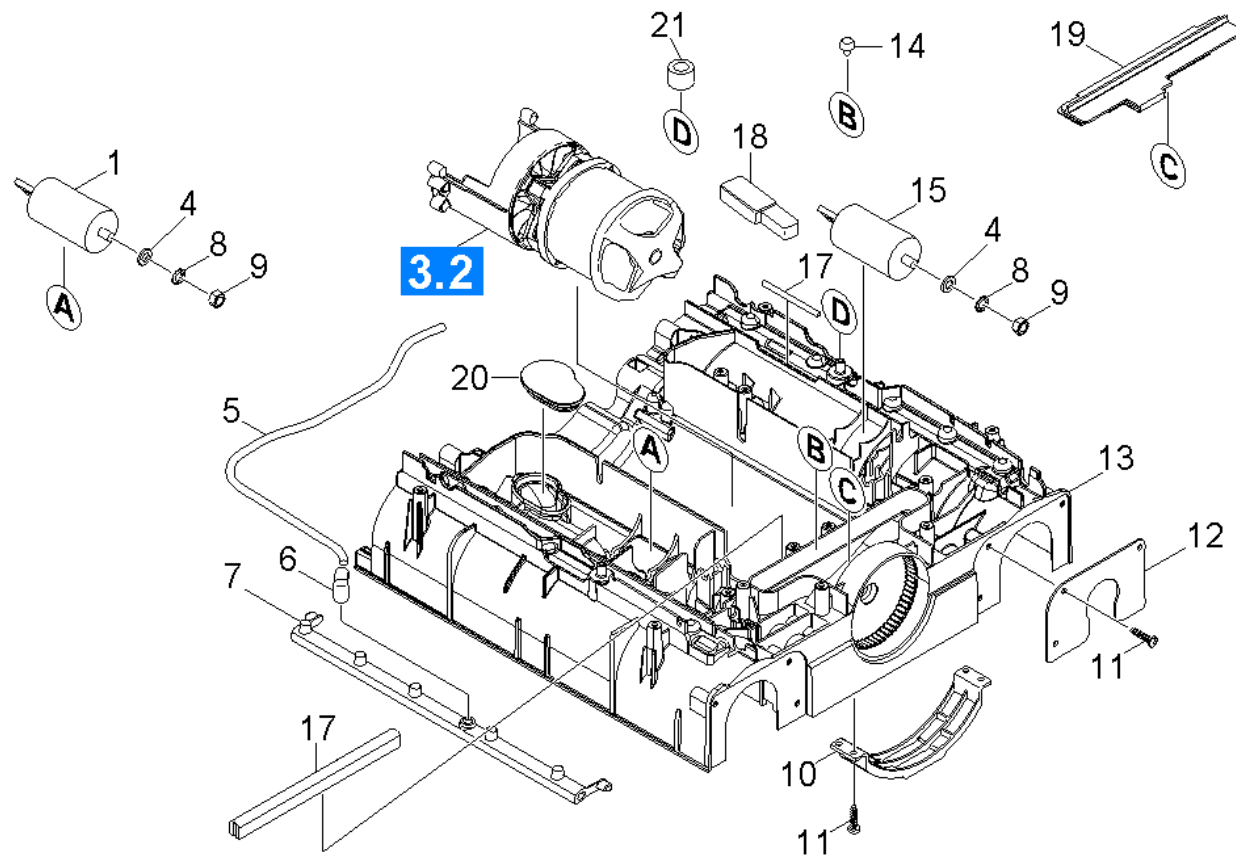

31 Brush housing

POS	Article no.	Description	Quantity	Unit	Foot note text
1	6.661-220.0	Capacitor	1.000	ST	
4	7.312-004.0	Washer 8 -200HV-A3E ISO 7089	2.000	ST	
5	6.388-216.0	Hose DN 5	1.000	M	TO ORDER AS CUT GOODS
6	5.050-411.0	Angle bushing water distribution	2.000	ST	
7	5.050-992.0	Water distributor	2.000	ST	
8	7.312-233.0	Serrated lock washer A8,4-FSt-A3E DIN67	2.000	ST	
9	7.311-004.0	Hexagon nut M8 -8-A3E ISO 4032	2.000	ST	
10	5.050-592.0	Edge protection	2.000	ST	
11	7.303-212.0	Screw 5x20 -A2-70 (In6Rd)	14.000	ST	
12	5.034-799.0	Plate brush holder	2.000	ST	
13	5.050-307.0	Brush housing	1.000	ST	
14	6.339-249.0	Rubber buffer motor	2.000	ST	
15	6.661-221.0	Capacitor	1.000	ST	
17	6.273-055.0	Profile gasket	2.000	M	TO ORDER AS CUT GOODS
18	6.682-975.0	Starting electronic MAS (d) 100-120V	1.000	ST	
19	5.050-421.0	Sealing carriage	1.000	ST	
20	5.050-422.0	Sealing air circulation	1.000	ST	
21	5.034-894.0	Joint ring	2.000	ST	

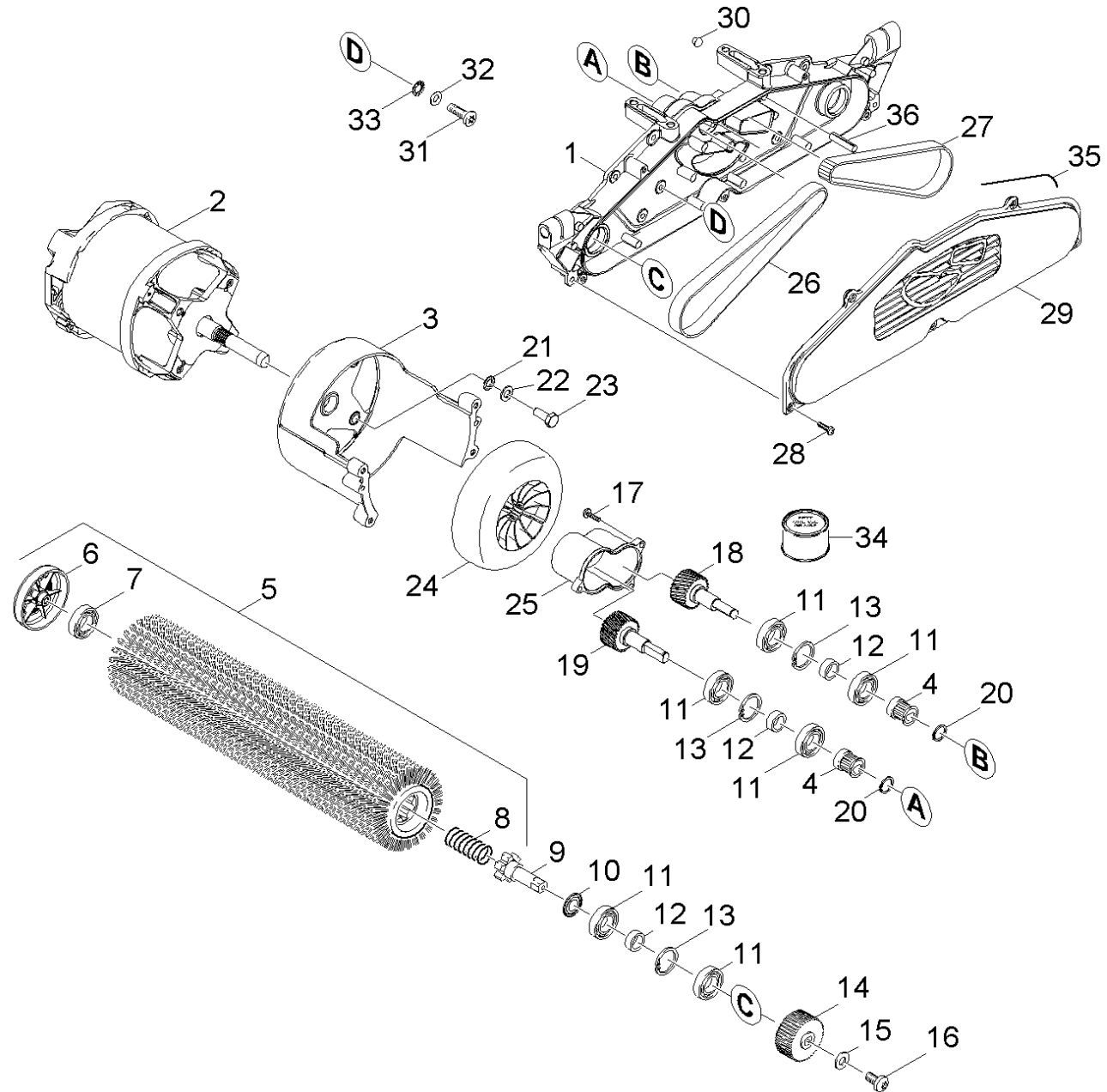

32 Transmission

POS	Article no.	Description	Quantity	Unit	Remark	Foot note text
1	5.050-445.0	Gear case worked	1.000	ST		
2	6.680-046.0	Electric motor 1,1 kW 120 V	1.000	ST		
3	5.050-432.0	Flange motor worked	1.000	ST		
4	5.625-318.0	Belt pulley 21Z	2.000	ST		
5	4.762-274.0	Roller brush horsehair nature BR VS 400	2.000	ST		
5	4.762-252.0	Roller brush green (old colour grey)	2.000	ST		
5	4.762-481.0	Roller brush black complete	2.000	ST		
5	4.762-251.0	Roller brush orange (old colour red)	2.000	ST		
5	4.762-003.0	Roller brush red complete	2.000	ST		
5	4.762-250.0	Roller brush white (old colour black)	2.000	ST		
6	4.038-677.0	Sheet metal component thread deflector	2.000	ST		
7	6.401-363.0	Ball bearing	2.000	ST		
8	5.332-114.0	Helical spring	2.000	ST		
9	5.100-571.0	Driveshaft 59mm	2.000	ST		
10	6.363-292.0	Joint ring NILOS 6002	2.000	ST		
11	7.401-115.0	Ball bearing 6002-2RS -WAE LZLAGST DIN 62	8.000	ST		
12	5.110-686.0	Spacer sleeve	4.000	ST		
13	7.343-231.0	Locking ring 32x1,2 -St-ph DIN 472	4.000	ST		
14	5.625-357.0	Belt pulley 56Z HTD 3M	2.000	ST		
15	7.312-292.0	Washer 6 -A2 ISO 7093-1	2.000	ST		
16	6.304-180.0	Screw M6X12-A2/70-ISO7045 (IN6RD)	2.000	ST		
17	7.303-039.0	Screw M5x16 -St-P2R (In6Rd)	3.000	ST		
18	4.100-234.0	Shaft gear right	1.000	ST		
19	5.105-684.0	Shaft transmission left	1.000	ST		
20	7.343-003.0	Locking ring 12x1-Rf-St DIN 471	2.000	ST		
21	7.312-233.0	Serrated lock washer A8,4-FSt-A3E DIN67	4.000	ST		
22	7.312-017.0	Washer 8-A2 ISO 7089	4.000	ST		
23	7.304-397.0	Hexagonal head screw M8x20-8.8-A2E ISO	4.000	ST		
24	5.050-358.0	Blower wheel	1.000	ST		

32 Transmission

POS	Article no.	Description	Quantity	Unit	Remark	Foot note text
25	5.050-357.0	Cover gear	1.000	ST		
26	6.348-444.0	Toothed belt HTD-420-3M-15 CXPIII	1.000	ST		
27	6.348-431.0	Toothed belt HTD-474-3M-15 CXPIII	1.000	ST		
28	7.303-039.0	Screw M5x16 -St-P2R (In6Rd)	6.000	ST		
29	5.050-310.0	Cover gear case	1.000	ST		
30	6.368-347.0	Cap D5	1.000	ST		
31	7.306-105.0	Screw M6x30 -8.8-R3R (In6Rd)	4.000	ST		
32	7.312-003.0	Washer 6 -200HV-A3E ISO 7089	1.000	ST		
33	7.312-232.0	Serrated lock washer A6,4-FSt-A3E DIN 6	4.000	ST		
34	6.288-095.0	Viscous oil	1.000	ST	50g	
35	6.273-037.0	Seal string cellular rubber 3	1.000	M		TO ORDER AS CUT GOODS
36	7.314-944.0	Spring pin 5x24-St ISO 8752	2.000	ST		

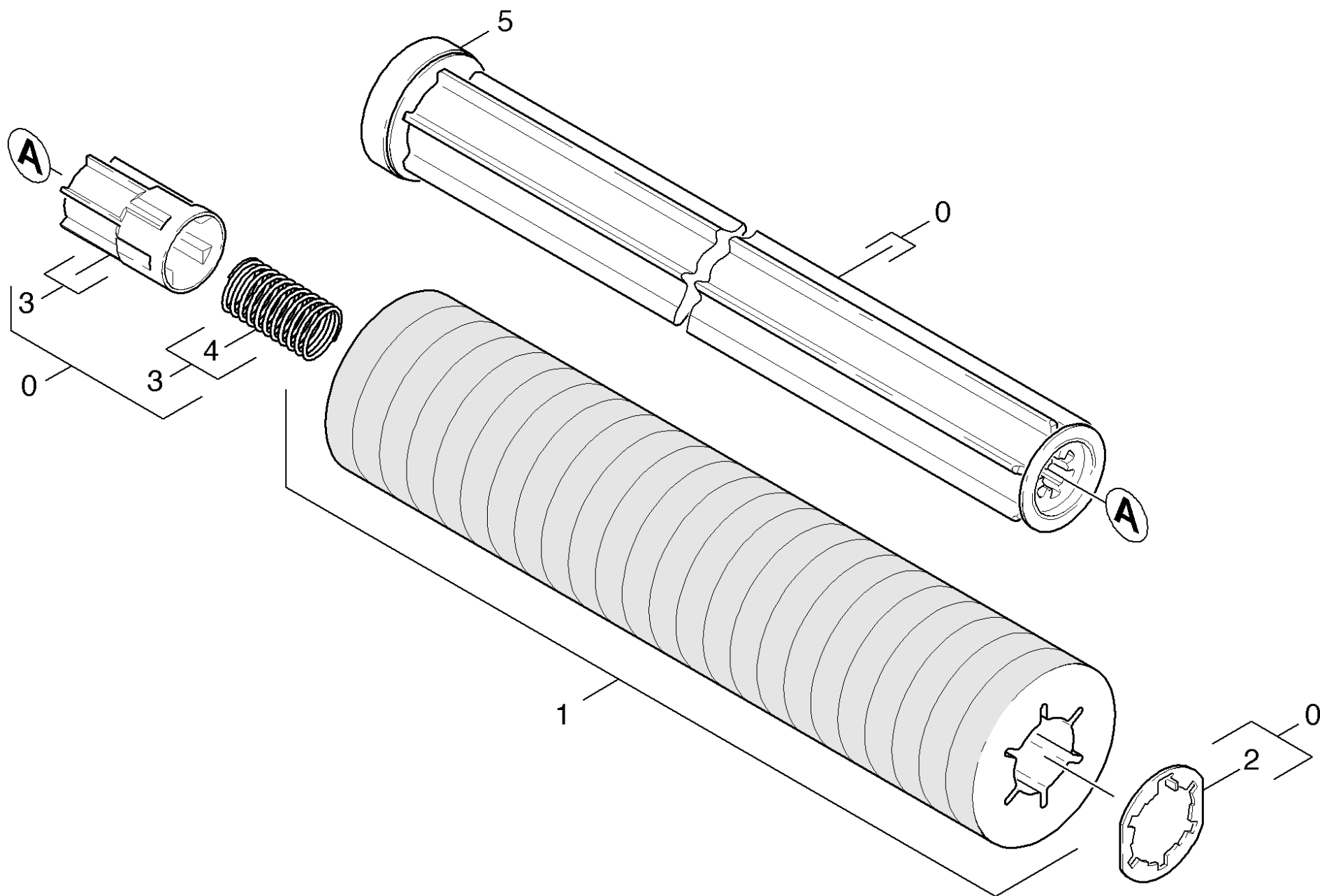

40 Accessories pad roll

POS	Article no.	Description	Quantity	Unit
0	4.762-228.0	Roll Pad BR VS 400	1.000	ST
1	6.369-726.0	Pad red with sleeve	1.000	ZSA
1	6.369-727.0	Pad white with sleeve BR VS 400	1.000	ZSA
1	6.369-724.0	Pad yellow with sleeve	1.000	ZSA
1	6.369-725.0	Pad green with sleeve	1.000	ZSA
2	4.115-003.0	Washer closure	1.000	ST
3	5.120-313.0	Hub pad roll BR VS	1.000	ST
4	5.332-469.0	Helical spring	1.000	ST
5	4.038-677.0	Sheet metal component thread deflector	1.000	ST

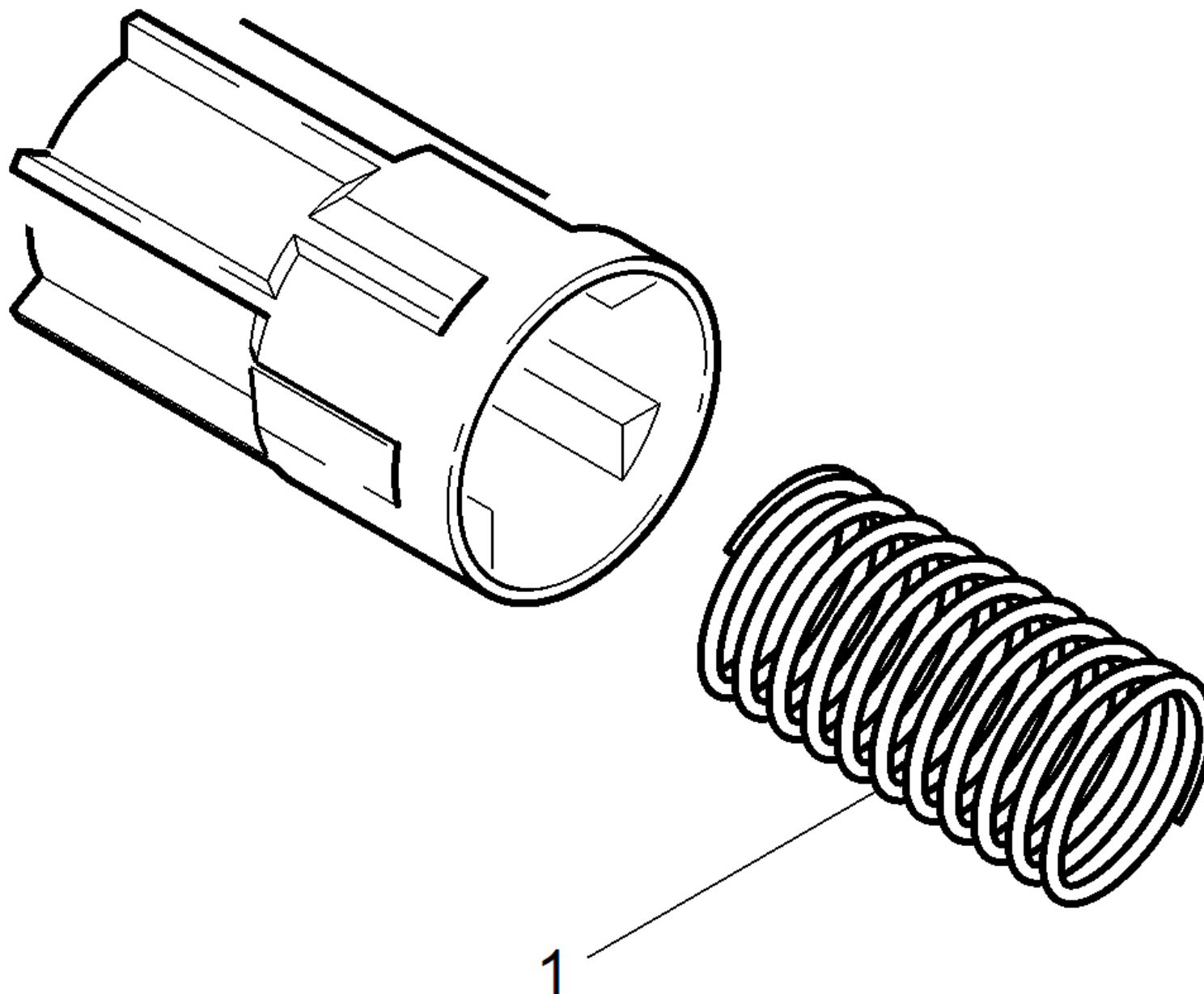

3 Hub pad roll BR VS (5.120-313.0)

POS	Article no.	Description	Quantity	Unit
1	5.332-469.0	Helical spring	1.000	ST
